



USER'S MANUAL

WP-DC

WhisperPower DC Beltpower

12/90 12/130 12/160
24/75 24/110 24/150



DC alternator with three-step charge regulator

The lean and mean on-board power generating system



- High charge current at low rpm of the alternator
- Recharging the battery for the full 100% within a short period
- Three-step charge algorithm, suitable for GEL, AGM and 'wet' batteries
- Extends battery life considerably
- Temperature sensor included
- Waterproof IP 65 enclosure

1. INTRODUCTION

Thank you for choosing a professional quality product from WhisperPower. WP-DC Beltpower is a system designed to be driven by a belt from a pulley on a vehicle's or ship's propulsion engine. In most cases an additional pulley has to be installed. The alternator's output is connected to the WP-ACR, which converts and regulates the incoming alternating current in order to charge a 12 or 24 Volts battery bank using a state-of-the-art charge algorithm.

This manual is valid for the following products:

Part number	Description
60212091	WP-DC Beltpower 12V/90A Alternator
60212131	WP-DC Beltpower 12V/130A Alternator
60212161	WP-DC Beltpower 12V/160A Alternator
60115100	WP-ACR 12V Alternator Charge Regulator
60224076	WP-DC Beltpower 24V/75A Alternator
60224111	WP-DC Beltpower 24V/110A Alternator
60224151	WP-DC Beltpower 24V/150A Alternator
60115200	WP-ACR 24V Alternator Charge Regulator

Safety guidelines and measures

This manual serves as a guideline for safe and effective installation and use of the WP-DC Beltpower. It should be kept in a dry and clean place, and be available any time. Please read this manual carefully before installing and using your WP-DC Beltpower.

Throughout this manual, the following alert symbol is used to indicate potential hazard:

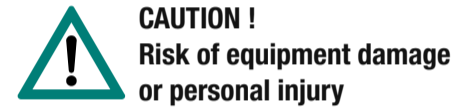

Always be aware that your actions may have an impact on safety and/or on product performance. Carefully follow instructions documented.

2. INSTRUCTIONS FOR USE

Use the WP-DC Beltpower for intended purpose only:

- to charge batteries and to supply loads connected to these batteries, in permanent systems;
- with fuses protecting the wiring between the system components and the battery;
- in a technically correct condition;
- in a closed, well-ventilated room, protected against rain, moist, dust and condensation;
- observing the instructions in this manual.

WhisperPower is not liable for any damage caused by using the WP-DC Beltpower for other purposes and in other ways than mentioned above.

CAUTION ! Battery acid is corrosive; wear protective eyewear when handling batteries. If battery acid would come in contact with eyes, rinse with a lot of water for a minimum of 15 minutes and seek medical attention.

WARNING ! Never keep the WP-DC Beltpower active when the engine is off. Otherwise, alternator windings will become overheated.

WARNING ! Never use the WP-DC Beltpower in locations where there is a risk of explosion due to gases, potentially flammable products or dust.

Little instruction is needed to operate the WP-DC and WP-ACR. Once installed as described in Section 4, the alternator will function with minimal user interaction.

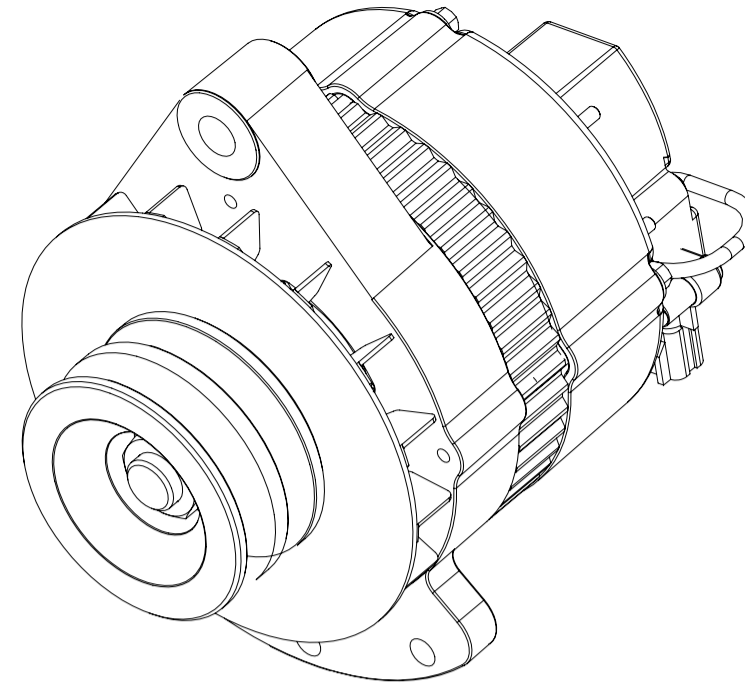

Monitoring and control

Refer to Figure 1: the battery charging performance can be monitored by means of the WP-ACR display.

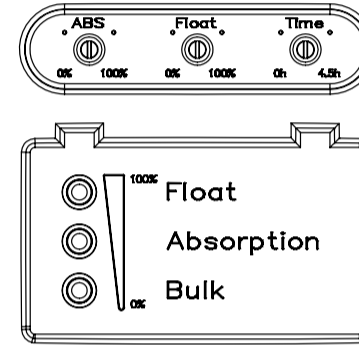

Figure 1: ACR front display

The WP-ACR controls the alternator's output voltage. It monitors and manages the best charge process available for lead-acid, gel and AGM batteries. The three automatic charging stages are shown by their corresponding LEDs: Bulk (yellow), Absorption (yellow) and Float (green).

A schematic view of the three-step charging process is presented in Figure 2.

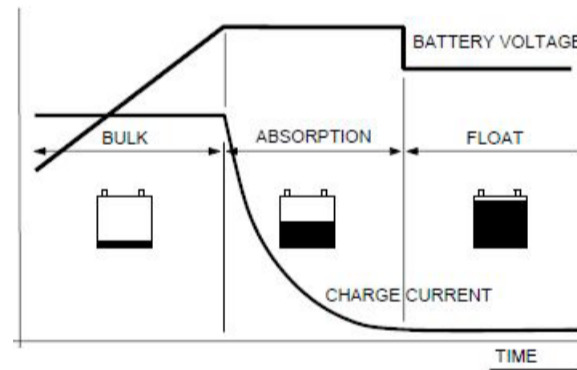

Figure 2: Three-step battery charging curve

Temperature-compensated charging

The delivery includes a battery temperature sensor enabling the WP-ACR to adapt the charge voltages to the battery temperature, as shown in Figure 3. This will extend the life of your batteries.

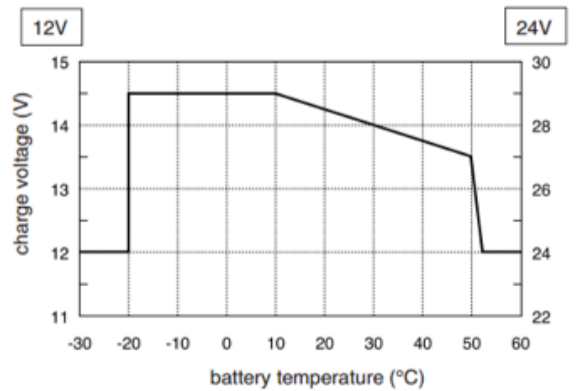

Figure 3: Battery temperature compensation curve

Maintenance and repair

Use only original spare parts.

CAUTION ! When service has to be carried out while the engine is running, be aware of moving parts !

WARNING ! Make sure the WP-DC Beltpower and engine are secured against unexpected and unintentional switching on when switched off for maintenance or repair.

- Remove the key from the engine ignition switch;
- Disconnect the batteries or remove the DC fuse(s);
- Be sure that third parties cannot reverse the measures taken.

Electrical connections:

- Check the wiring at least every six months. Burned cables, poor connections etc. must be corrected immediately.

Technical drawings

Note: additional drawings of all BeltPower types can be obtained from the WhisperPower website.

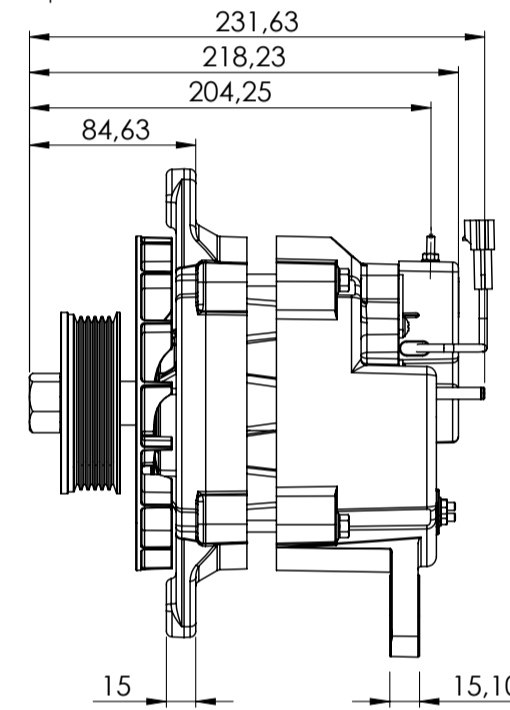

Alternator condition:

- Check the alternator at least every six months. Alternator surfaces should not show any buildup of dirt, grease or dust. Air flow passages must also be clear so that air can easily pass through the unit. The alternator's bearings are greased for life and do not require maintenance

Alternator mounting, belt tension and condition:

- Check the mounting of the alternator as well as belt tension and condition after the first 50 running hours, then every 150 running hours or at least every year, whichever comes first.
- Check if the alternator is securely mounted to its brackets and that the brackets are bolted securely to the engine.
- Before adjusting belt tension, inspect the belt for glazing, cracks, or dryness. If the belt is in satisfactory condition, check its tension with a belt tension gauge. Loose belts will slip on the pulley, fail to turn the alternator's rotor and finally overheat the alternator. Adjust if necessary, following the instructions given in the installation section.
- A worn or damaged belt should be replaced. After installing a new belt, run the engine with full load connected to the alternator for approximately 15 minutes. Then check the belt tension again and adjust it if necessary.

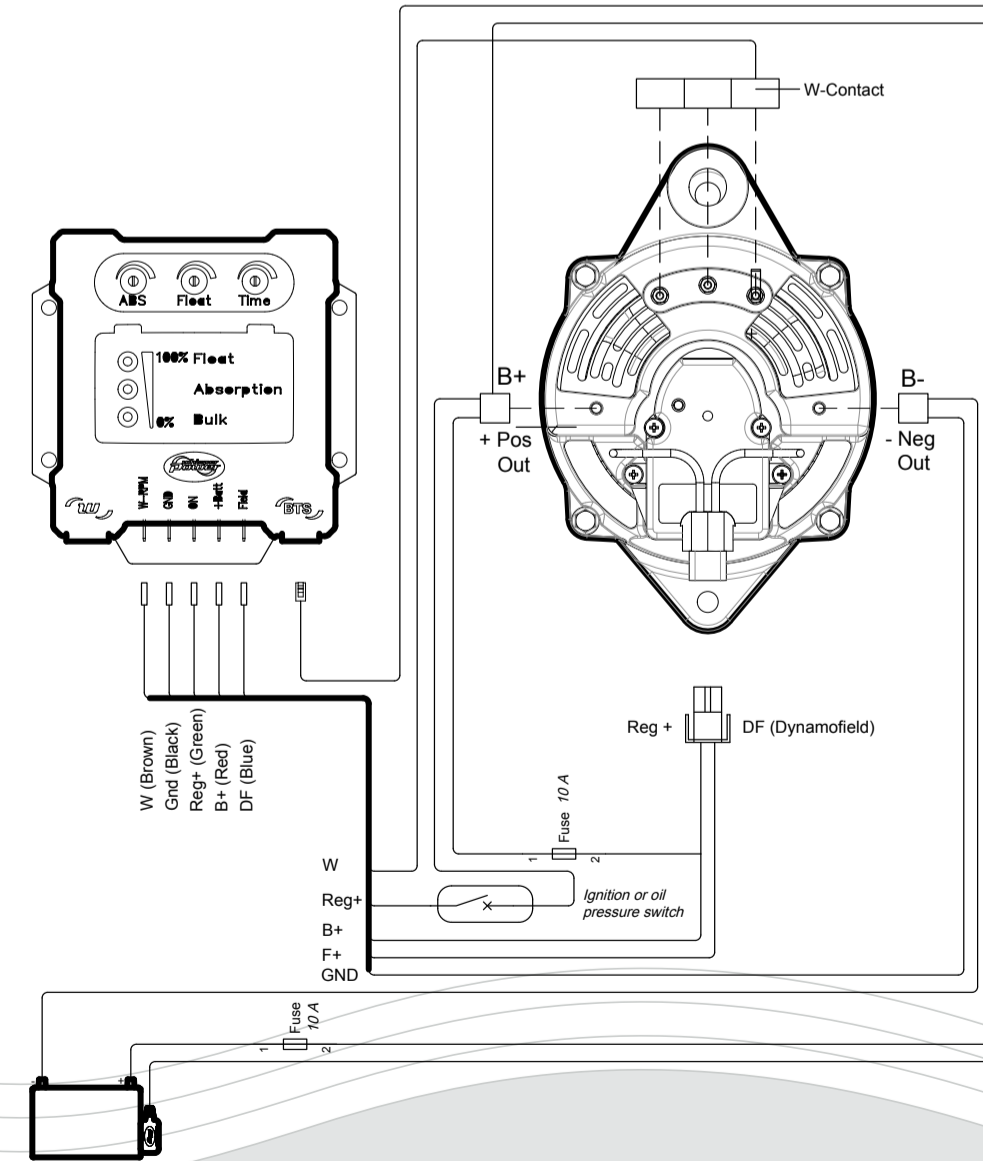
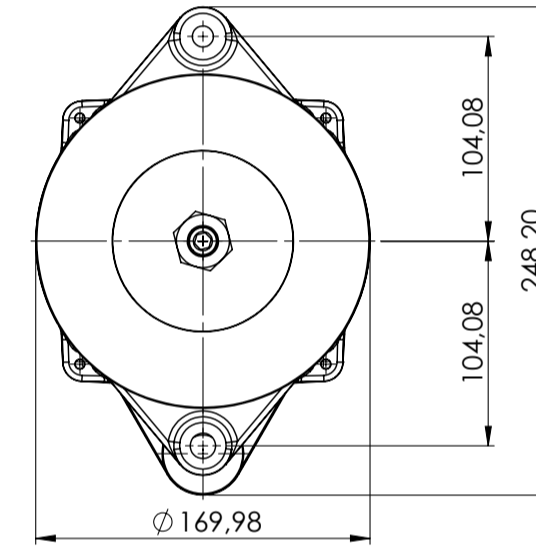

3. TROUBLESHOOTING

In case of any fault, it is recommended to consult the 'Maintenance and repair' section before checking the table below. If necessary, contact your local WhisperPower Service Centre. See www.whisperpower.com.

Problem	Possible cause	Solution
Alternator is getting hot while engine is not running.	Rotor field windings are excited while they should not.	Switch off DC to prevent field windings from being damaged by overheating. Check oil pressure switch/ignition relay for correct operation (circuit must be broken when engine is not running).
No voltages at all, LEDs are off.	Battery fuse is blown. Battery connections are bad. Black [gnd] wire is loose.	Replace the fuse. Clean connections. Replace cables if burned. Reconnect black [gnd] wire.
No output power, all LEDs are off. [+batt] on WP-ACR is 12/24V, [reg on] is OV.	Engine is not running. Fuse in brown wire is blown. Brown [reg on] wire is loose. Faulty oil pressure switch or ignition relay (S1).	Start the engine. Replace the fuse. Reconnect brown wire. Replace faulty item.
No output power, one of the LEDs is on. [field] on WP-ACR is OV.	Fuse in red wire is blown. Two pole (red and blue) field connector is loose. Problem in the wiring. Blue [field] wire is loose. Field windings of the alternator are defective.	Replace the fuse. Check field connector on the alternator. Check red and blue wires to the field connector. Reconnect blue wire. Check resistance of field windings. Replace alternator.
No output power, all LEDs are off. [reg on] and [+batt] on WP-ACR are 12/24V.	Black [gnd] wire is loose. WP-ACR defective.	Reconnect black [gnd] wire. Replace WP-ACR.
Regulator stays in bulk mode all the time.	Alternator is overloaded. Defective batteries, short-circuit between cells. Capacity of the charging system is too low. Defective WP-ACR.	Switch off a load. Check batteries and replace if necessary. Use a more powerful alternator. Consult WhisperPower for advice. Replace WP-ACR.
WP-ACR does not return to bulk mode when a high load is switched on.	The absorption timer keeps the WP-ACR in absorption mode. When in float mode, the regulator will stay in this mode.	Nothing: this is a normal situation. If necessary switch off engine and start again.
Output voltage is too high.	The regulator measures a too low battery voltage and tries to compensate. Wrong setting of the charge voltage. WP-ACR cannot sense battery temperature.	Check wiring between battery and [on] for corrosion. The line should not be used by other loads. Check for voltage drop across oil pressure switch (if installed). Adjust the charge voltage. Connect battery temperature sensor or attach to batteries.
Absorption time is too long/short.	Wrong setting of the absorption timer.	Adjust the absorption timer.
WP-ACR is in float mode, but battery voltage is still at absorption or bulk level.	Another device is charging the batteries.	Switch off all other charging devices and check the battery voltage again.

Disclaimer

WhisperPower can accept no responsibility for possible errors or omissions in catalogues, brochures and other printed material. WhisperPower reserves the right to alter its products without notice.

This guide must be followed carefully. WhisperPower can accept no responsibility for errors related to incorrect or unsafe installation and/or handling.



4. INSTALLATION

During installation and commissioning of the WP-DC Beltpower system, the Safety Guidelines & Measures are applicable at all times.

Unpacking

The delivery typically includes:

- WP-DC Beltpower Alternator
- WP-ACR Alternator Charge Regulator, including cable harness and temperature sensor
- This user's manual
- Installation drawings

You will also need an engine-specific mounting bracket for the alternator, a belt tensioner (in case of a multi-groove belt) and associated belt(s).

You will also need an engine-specific mounting bracket for the alternator and associated belt(s).

Check all items for possible (transport) damage. Do not use the product when damaged. If in doubt, contact your supplier. Check whether the nominal DC voltage is consistent for all applied components (e.g. a 12V alternator with a 12V WP-ACR and a 12V battery set).

Mounting the alternator (multi-groove belt)

1. Attach the alternator and its mounting bracket to the engine using flat washers, lock washers and bolts.
2. Similarly, mount the belt tensioner referring to the applicable instructions, if available.
3. Depending on the type of belt tensioner, push, pull or turn it out of the way and install the belt. Then carefully release the tensioner.
4. Check if the pulleys are properly aligned and correct if necessary. Check if the belt is tensioned such that it does not slip on the alternator fan pulley when you try to rotate the pulley by hand.
5. Check that all mounting bolts have been tightened using adequate torque (see table below).

Standard torque chart			
Size	M6x1.0	M8x1.25	M10x1.5
Nm*	10.8+1.0	25.5+2.9	49.0+4.9
* Apply 80% torque when tightening bolts to aluminum alloy.			

Mounting the alternator (V-belt)

1. Loosely attach the mounting bracket to the engine with the engine mounting bolts. Position the alternator mounting foot (A and B in the figure below) between the two ears on the mounting bracket using the alternator mounting bolts. The ear at the rear side of the alternator housing should be able to move freely in the direction of the arrow (A in the figure) in order to avoid mechanical stress.

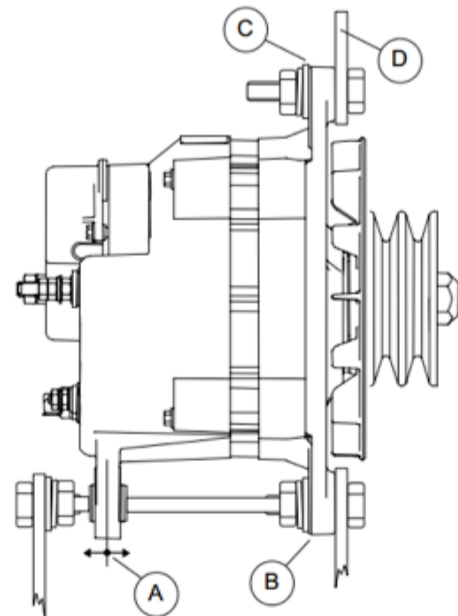

2. Align the alternator pulley with the engine drive pulley as shown below and tighten the bracket mounting bolts.

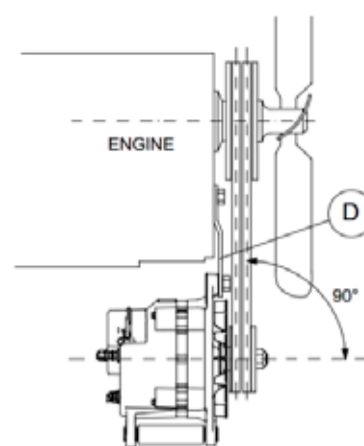

3. Loosely attach the alternator adjustment strap (D above) to the alternator adjustment ear (C) with the bolt, flat washer and lock washer.
4. Tighten the belt by applying pressure to the alternator front housing (the rear housing not being solid enough) and tighten the bolt to the adjustment ear (C). Set the belt tension in accordance with the manufacturer's specifications or, alternatively, such that the belt on alternator fan pulley will not slip when you try to rotate the alternator by hand.
5. Taking into account the 'Standard torque chart', tighten all remaining alternator mounting bolts and retighten all other bolts to secure the installation.

Mounting the WP-ACR

Install the WP-ACR not too far from the alternator, taking into account the length of the cable harness (1.5m).

Wiring instructions

Connect all items as shown in the installation drawings (refer to front page; additional drawings can be obtained from the WhisperPower website). All wiring is combined in the cable harness.

Apply battery cables as specified in the table below.

Recommended wire sizes and fuses:

Model	Wire = 3m	Wire > 3m	Fuse
12V / 90A	35mm ²	50mm ²	125A
12V / 130A	50mm ²	70mm ²	160A
12V / 160A	50mm ²	70mm ²	200A
24V / 75A	25mm ²	35mm ²	100A
24V / 110A	35mm ²	50mm ²	160A
24V / 150A	50mm ²	70mm ²	200A

Special attention is drawn to the brown and red wires in the cable harness:

- Refer to Figure 4: the green wire ('Reg+' / 'ON') must be connected to the engine ignition relay or, preferably, an ungrounded oil pressure switch.

- The red wire ('B+' / '+Batt') can be connected to the positive (+) pole of the battery or to the B+ terminal of the alternator.

However, if the DC Beltpower is meant to charge multiple batteries together with a WP-WBI Battery isolator, the red wire must always be connected to a positive (+) battery pole. Do not install the DC fuse in the positive cable until the installation is completed.

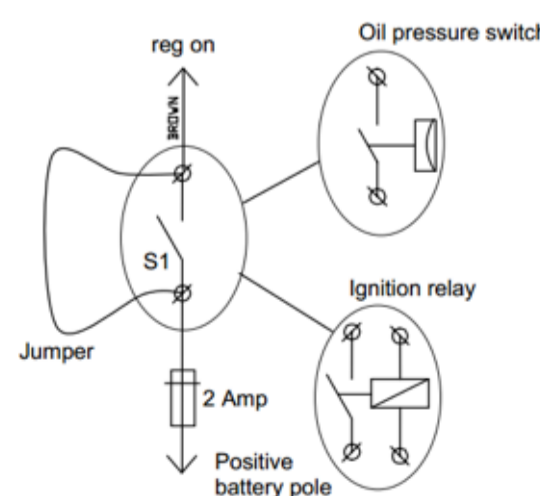

Figure 4: S1 switch connections

Commissioning checks

Before starting the engine follow all steps described below:

1. Check all wiring, then place the DC fuse(s) to connect the batteries to the alternator and to the WP-ACR.
2. Check whether all LEDs on the WP-ACR are off.
3. Energize the 'ON' terminal by either turning on the ignition switch (DO NOT START the engine) or by putting a jumper across switch S1 (also see Figure 4). Check whether the three LEDs start to blink. After some 10 seconds the yellow bulk LED will illuminate.
4. Check whether the alternator field is energized by touching the shaft of the alternator with a screwdriver. It should be strongly magnetic.
5. De-energize the [reg on] terminal by turning off the ignition switch or by removing the jumper. All LEDs should go off and the field should no longer be magnetic.



CAUTION !

Failure to de-energize the [reg on] terminal will damage the alternator's field windings.

If any of the above tests is unsuccessful, remove the DC fuses and double-check the wiring. Refer to the Troubleshooting section.

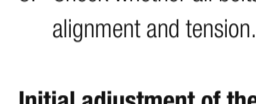

CAUTION !

Failure to de-energize the [reg on] terminal will damage the alternator's field windings.

Initial adjustment of the WP-ACR

The WP-ACR has three trimmer potentiometers for adjusting the absorption voltage, float voltage and absorption time. These must be set using a 0.4x2.5mm flat blade screwdriver.



CAUTION !

Invalid and especially too high settings can cause serious damage to your batteries or to sensitive equipment connected to these.



CAUTION !

Do not attempt to drive the potentiometers past their limits. You might damage them.

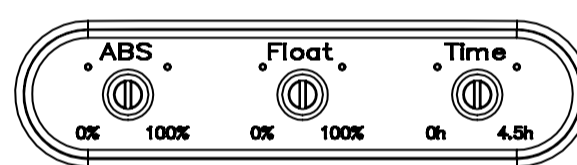

Absorption voltage:

- Turn the potentiometer counterclockwise until its stop, then rotate it 90° clockwise (approx. 14.25V/28.5V).

Float voltage:

- Turn the potentiometer counterclockwise until its stop, then rotate it 90° clockwise (approx. 13.25V/26.6V).

Absorption time:

- Turn the potentiometer clockwise until its stop, then rotate it 45° counterclockwise (approx. 4 hours).

The above settings may be adequate for some installations. However, it is strongly recommended to check the actual charge voltages in the absorption and float modes and to follow the detailed instructions for fine adjustment below.

In-operation testing and adjustment

For these tests, you will need to measure the voltage on the battery terminals in order to get the most accurate reading. Using the three potentiometers, you can adjust the charging system to the demands of the electrical installation.



CAUTION !

When the engine is running, be aware of moving parts like belts.



CAUTION !

Invalid settings of the potentiometers can cause serious damage to your batteries.

Refer to the battery manufacturer's specifications or use the generic settings mentioned below. Keep a record of setting changes.

Follow all steps described below:

1. Be sure no loads or any other charging sources are on. The battery should be fully charged. Disconnect the battery temperature sensor. Measure and record the battery voltage.
2. Start the engine.
3. Check for abnormal noise or vibration.
4. The yellow [bulk] LED on the WP-ACR will illuminate, indicating that the charge cycle begins.
5. Measure the battery voltage. It should be higher than at step 1. The battery voltage rises until the yellow [abs] LED illuminates.
6. The WP-ACR is now in absorption mode. When measured at 25°C / 77°F, battery voltage should stabilize at 14.25 ± 0.05V for a 12V alternator or 28.50 ± 0.10V for a 24V alternator.
7. Before adjusting the absorption voltage, increase the engine rpm slightly to verify that the charge voltage does not increase. If it does, either wait for the battery to become fully charged or find a high enough rpm where the voltage does not change with increasing rpm. Rotate the [abs] potentiometer carefully to set the absorption voltage at the desired value. With good wiring and good voltage sensing, the resolution should be within 0.03 Volt. Respect the limit specified by the battery manufacturer.
8. The absorption stage may take quite a while. For step 9 you might want to reduce the absorption time temporarily to 2 min by turning the [time] potentiometer counterclockwise until its stop.
9. When the absorption time has elapsed, the green [float] LED will illuminate. The WP-ACR is now in float mode. Wait for about 10 minutes to allow the battery voltage to settle. When measured at 25°C / 77°F, the battery voltage should stabilize at 13.25 ± 0.05V for a 12V alternator or 26.50 ± 0.10V for a 24V alternator.
10. If the float voltage needs to be adjusted, rotate the [float] potentiometer. When setting the float voltage near its lower limit, you may have to switch on some DC loads to trigger the alternator because it takes some time for the voltage to settle from the higher absorption voltage.
11. Stop the engine and reconnect the battery temperature sensor. Check belt alignment and tension, and adjust if necessary.
12. Finally, set the absorption timer. Adjustable range: 2 minutes up to 4.5 hours. The basic 4 hour setting is appropriate for most systems. Exceptions might be:
 - Extension of the absorption time to do some intentional overcharging to regain lost capacity.
 - Shorten the time if you stop and start the engine often each day.

If all of the above steps were successfully completed, the WP-DC Beltpower system is ready for operation. If not, check the Troubleshooting section.

5. SPECIFICATIONS

12V ALTERNATOR			
Model	12V/90A	12V/130A	12V/160A
Art. no.	60212090	60212130	60212160
GENERAL			
Power (continuous)	1080W	1560W	1920W
Max. current (continuous)	90A	130A	160A
Voltage	12VDC		
MECHANICAL			
Dimensions (h x w x d)	195 x 205 x 140mm	250 x 225 x 175mm	
Net weight	5.5kg	10.1kg	
Mounting style	Spool 86	J180	
Bi-directional	Yes	Yes	Yes
ACCESSORIES / ADDITIONAL MATERIALS			
WP-WBI 150-2IG Battery isolator	60115002	Choose alternative battery isolator	
Standard pulley	60212001	60212006	
Optional pulley	60212002	60212005	

24V ALTERNATOR			
Model	24V/75A	24V/110A	24V/150A
Art. no.	60224075	60224110	60224150
GENERAL			
Power (continuous)	1800W	2640W	3600W
Max. current (continuous)	75A	110A	150A
Voltage	24VDC		
MECHANICAL			
Dimensions (h x w x d)	250 x 225 x 175mm	250 x 250 x 185mm	
Net weight	10.1kg	13.1kg	
Mounting style	J180	Spool 213	
Bi-directional	Yes	Yes	Yes
ACCESSORIES / ADDITIONAL MATERIALS			
WP-WBI 150-2IG Battery isolator	60115002		
Standard pulley	60212006		
Optional pulley	60212005		

6. WARRANTY TERMS AND CONDITIONS

WhisperPower guarantees that the equipment has been produced in accordance with the legally applicable standards and specifications. WhisperPower assures the product warranty of the WhisperPower DC Beltpower during two years after purchase, on the condition that all instructions and warnings given in this manual are taken into account during installation and operation. The warranty is limited to the costs of repair and/or replacement of the product by WhisperPower only. Costs for installation labor or shipping of the defective parts are not covered by this warranty.

2004/108/EC (EMC Directive)
EN61000-6-3:2007 (Electromagnetic compatibility [EMC]. Generic standards. Emission standard for residential, commercial and light-industrial environments)
EN61000-6-1:2007 (Electromagnetic compatibility [EMC]. Generic standards. Immunity for residential, commercial and light-industrial environments)
2006/95/EC (Low Voltage Directive)
EN60950:2000 (Safety of information technology equipment)

WP-ACR CHARGE REGULATOR		
Model	12VDC	24VDC
Art.no.	60115100	60115200
GENERAL		
Nominal voltage	12VDC	24VDC
Temperature sensor	Yes, cable length 6m	
Cable harness	Yes, length 1.5m	
Connection plug regulator / alternator	WhisperPower alternator	
Alternator type	WhisperPower, low voltage, brush type	
ELECTRICAL		
Charge voltage - Absorption	14.25VDC	28.50VDC
Charge voltage - Float	13.25VDC	26.50VDC
Absorption voltage range	13 .. 15VDC	27 .. 31VDC
Float voltage range	13 .. 13.9VDC	26 .. 27.8VDC
Absorption time	0 .. 4.5h	
Temperature compensation	-30mV/°C	-60mV/°C
Rev counter input	Prepared	
Operating temperature range	-20 .. 80°C	
SETTINGS / READ OUT		
Voltage settings	By trimmers on device	
Time settings	By trimmers on device	
Status read-out	LEDs	
Communication bus	WhisperConnect prepared	
MECHANICAL		
Dimensions (h x w x d)	117 x 120 x 27mm	
Weight	0.4kg	
Packaging size (h x w x d)	330 x 230 x 65mm	
Protection degree	IP65	

7. CE MANUFACTURER'S DECLARATION

Issuer's name: WhisperPower BV
Issuer's address: Kelvinlaan 82, NL-9207 JB Drachten

Object of the declaration:
WhisperPower alternators and regulators,
Article nos. 60212091, 60212131, 60212161, 60115100, 60224076, 60224111, 60224151 and 60115200.

The object of the declaration described above is in conformity with the requirements of the following Directives and standards, as applicable:

2004/108/EC (EMC Directive)
EN61000-6-3:2007 (Electromagnetic compatibility [EMC]. Generic standards. Emission standard for residential, commercial and light-industrial environments)
EN61000-6-1:2007 (Electromagnetic compatibility [EMC]. Generic standards. Immunity for residential, commercial and light-industrial environments)
2006/95/EC (Low Voltage Directive)
EN60950:2000 (Safety of information technology equipment)

Signed for and on behalf of:

WhisperPower BV

M. Favot
Chief Technical Officer

Drachten, October 7, 2014



SYSTEM DRAWINGS

WP-DC

WhisperPower DC Beltpower

12/90 12/130 12/160
24/75 24/110 24/150

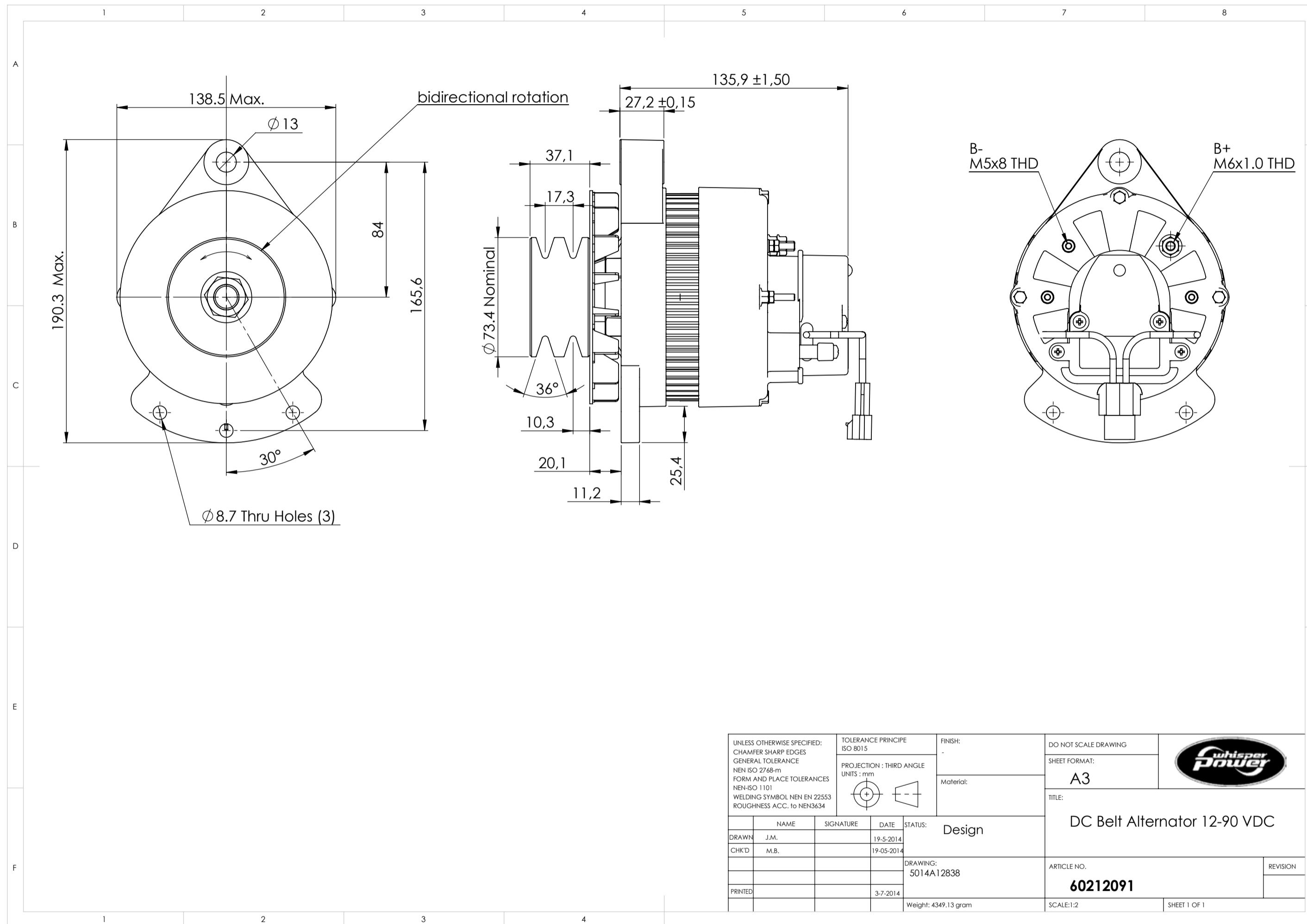



SYSTEM DRAWINGS

WP-DC

WhisperPower DC Beltpower

12/90 12/130 12/160
24/75 24/110 24/150

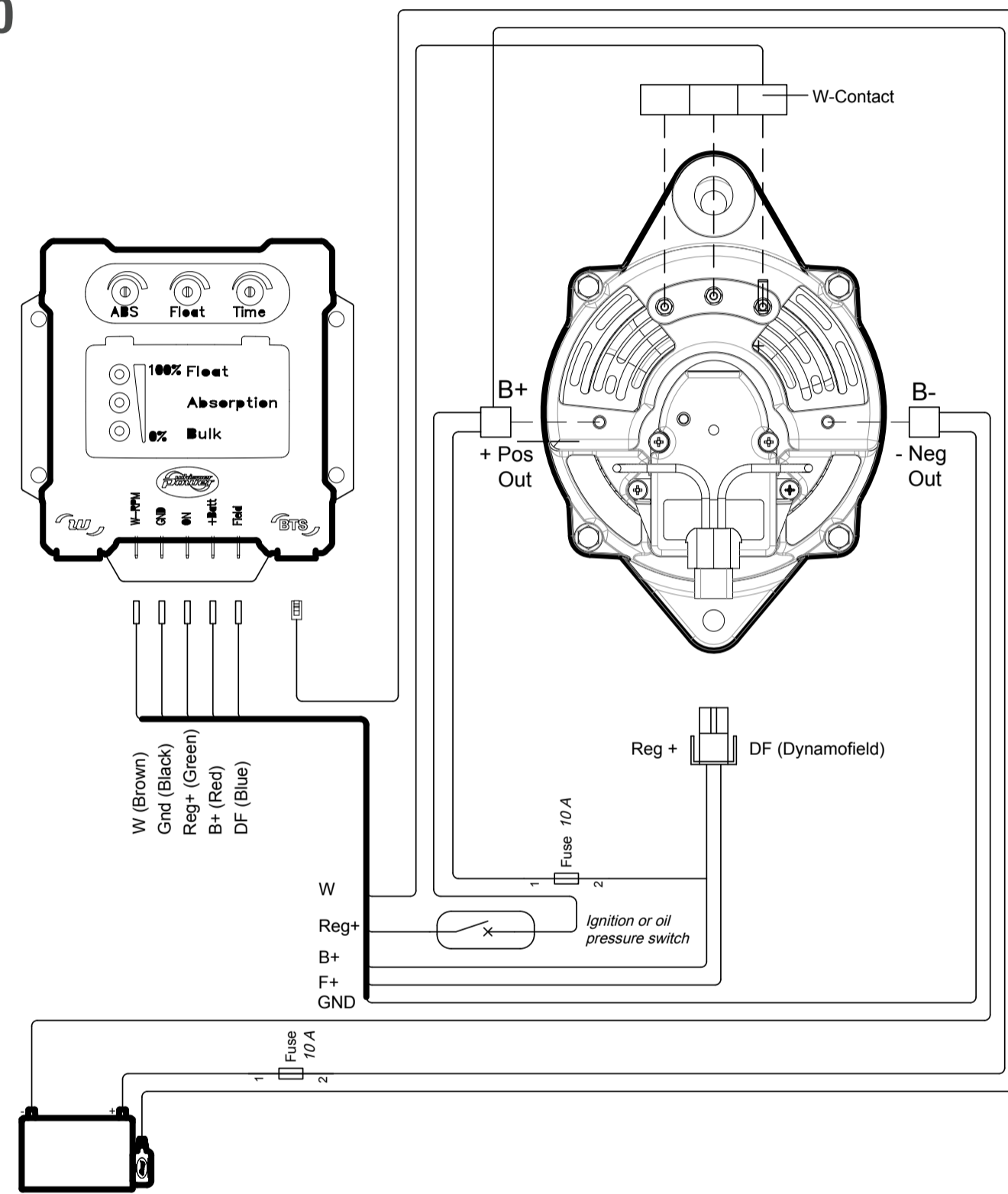

Design		7012 single line diagram dc belt power installation 12 VDC battery bank			
NAME	SIGNATURE	DATE	SHEET FORMAT	ARTICLE NO.	REVISION
DK'S		11-26-14	A2	9500SL0401 Single battery bank	

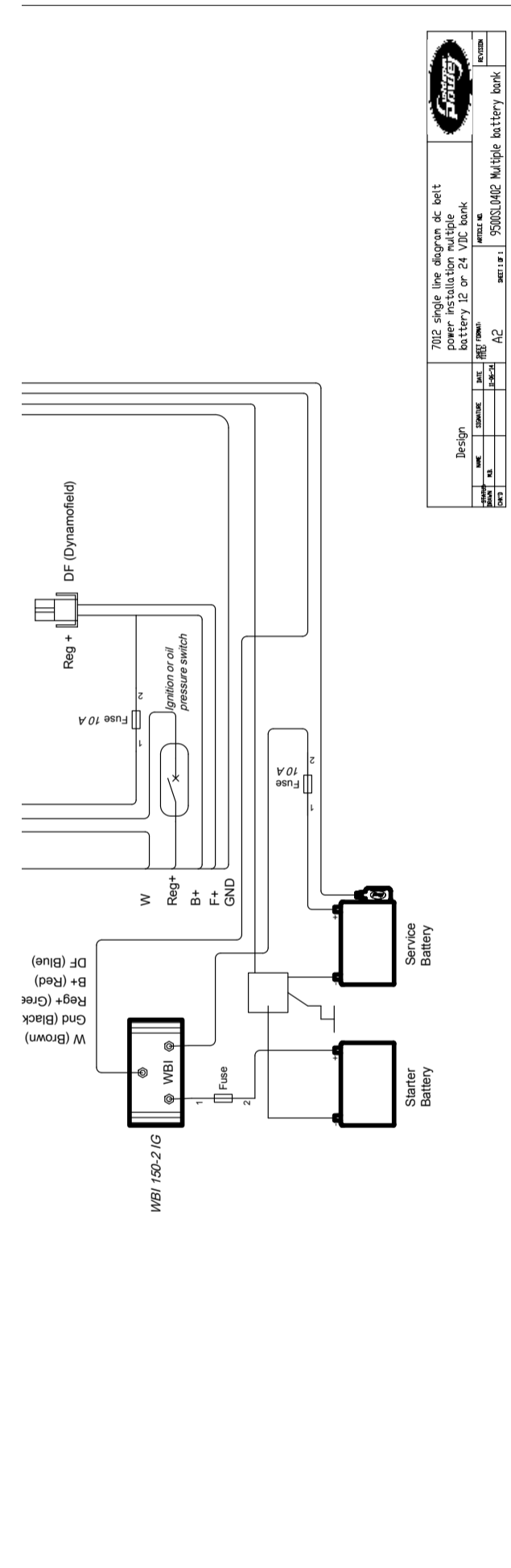

7012 single line diagram dc belt power installation 12 VDC battery bank		9500SL0401 Multiple battery bank	
Design	DK'S	DATE	11-26-14
SHEET	A2	SHEET	1 OF 1

