

# FURLEX

104S

204S

304S

404S



The **4th** generation of an icon

 **SELDÉN**  
*for sailing*

## For carefree sailing

The fourth generation of Furlex is an uncompromising evolution of the world's best selling jib furling and reefing system. Proven design blended with innovation is our way to maintain the iconic heritage of Furlex.



The halyard swivel for Furlex 104S and 404S features stainless ball bearings. The load is centered by the attachment of the Dyneema® lashing.



The sail feeder is marine grade stainless steel. It is well rounded and kind to the sail.

The twin-groove luff extrusion and the split drum allow the racing sailor to convert the Furlex for racing. The cruising sailor can use the extrusion for 'wing on wing' downwind sailing with two genoas poled out to either side.

**NEW** Two sets of stainless ball bearings and one additional set of roller bearings for low friction and low lateral deflection.

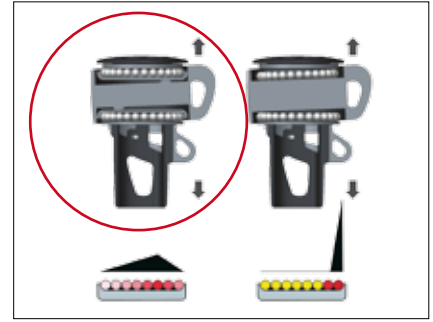
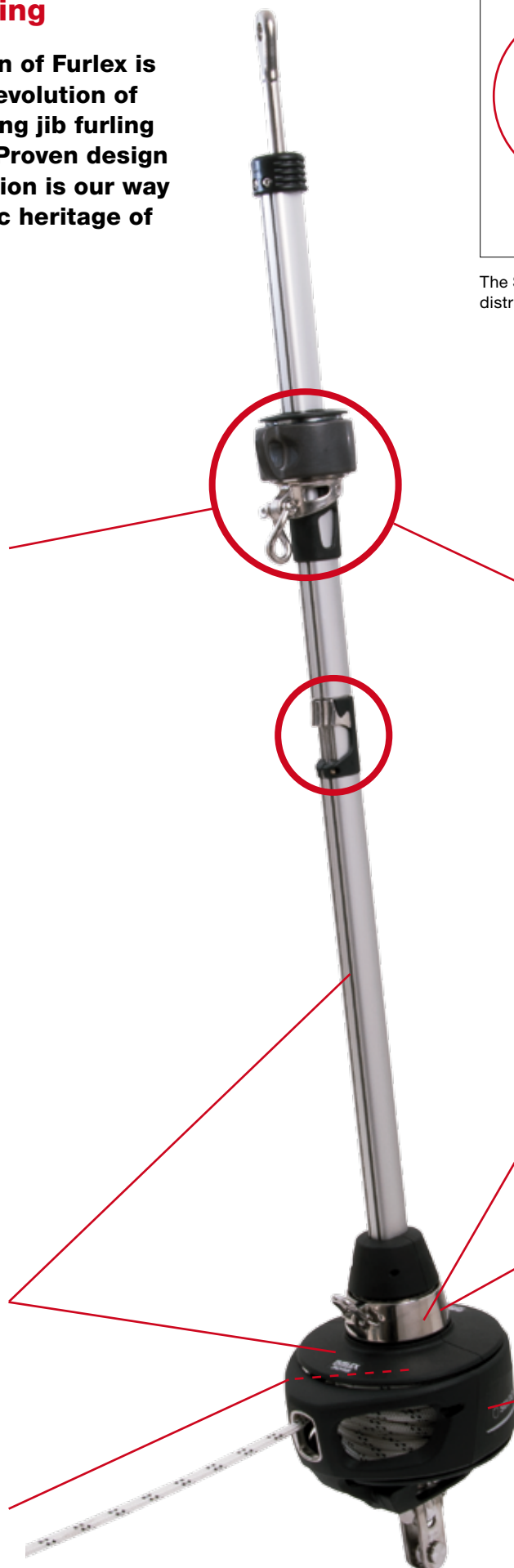

The Seldén load distributor prevents... ..point loading!



Ball bearings and ball bearing races made from marine grade stainless steel. Seldén's patented load distributor for Furlex 204S and 304S makes for low furling resistance and durability. This concept was launched in 1983 and it still performs flawlessly today.

Tack swivel with a 'free-turn' and a uniform cross section of the luff extrusion make for a perfectly furled sail and effective performance even when reefed. It also reduces the effort needed to furl that first turn.

**NEW** The tack ring has a smaller diameter compared to previous models and the shackle is also smaller. This combination reduces the initial furling resistance.

**NEW** Greater utilisation of modern composite material means 8% overall weight reduction which improves the sailing performance.

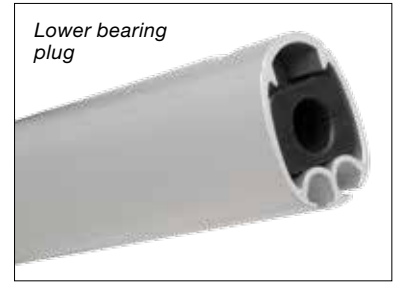
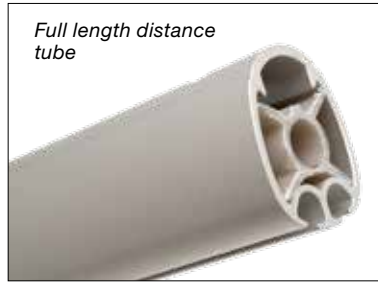

The forestay wire is centred and insulated the full length of the extrusion enabling the extrusion to rotate evenly around the wire. The furling resistance is reduced and chafe between the wire and the extrusion is eliminated.



**NEW** The luff extrusion consists of 2400 mm sections connected with an aluminium joining sleeve and a stainless steel connecting plate. The joining sleeve transmits the torque within the extrusions, and the connecting plates keep the sections together with a slight gap between them. This way chafe is avoided on both the extrusions and the sail.

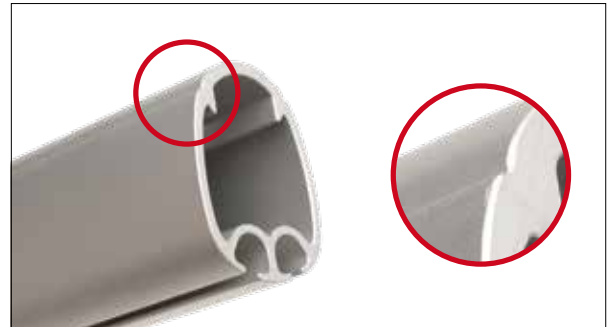

**NEW** The Furlex Aero Groove system reduces drag and creates improved flow over the luff extrusion and consequently, the sail.

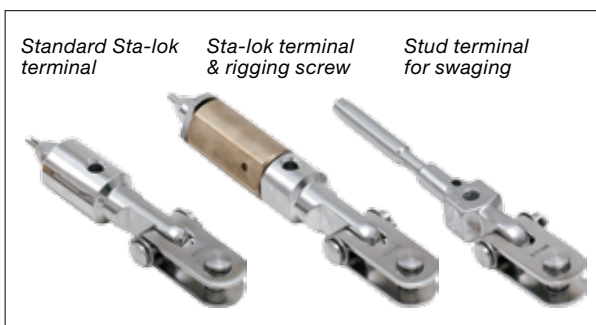

Similar to previous Furlex models, the standard kit requires that the wire is cut to length and fixed with a 'Sta-lok' mechanical wire locking system. A completely integrated rigging screw is offered as an option. It allows for adjustment of the forestay length without altering the height of the tack attachment.

**NEW** To simplify the final assembly at the dock, Furlex can now also be ordered with the forestay wire pre-cut to a specific length. Both ends of the wire are fitted with swaged terminals and the lower stud terminal can pass through the extrusions. This method of assembly does not include the option of an integrated rigging screw.



Furlex, as in previous generations, comes as a complete kit including all parts needed for reliable and convenient furling of the foresail. It even includes a new forestay wire, furling line, stanchion lead blocks, a halyard lead and a prefeeder. A simple purchase.

**NEW** If you already have a jib furler on your boat and do not need another set of stanchion blocks, halyard lead, prefeeder and Torx bits you can order a Basic kit in which these parts are excluded.

## Complete kit



Complete kit.

Furlex	Forestay dia. Ø mm	Max. forestay length, mm	Complete kit including...		
			Standard Sta-lok terminal Art. No.	Sta-lok terminal & rigging screw Art. No.	Stud terminal for swaging Art. No.
104S	4	8100	030-020-51	030-020-61	030-020-91
		10500	030-020-52	030-020-62	030-020-92
	5	8100	030-020-53	030-020-63	030-020-93
		10500	030-020-54	030-020-64	030-020-94
		12900	030-020-55	030-020-65	030-020-95
	6	10500	030-020-56	030-020-66	030-020-96
12900		030-020-57	030-020-67	030-020-97	
204S	6	10550	035-025-51	035-025-61	035-025-91
		12950	035-025-52	035-025-62	035-025-92
		15350	035-025-53	035-025-63	035-025-93
	7	12950	035-025-54	035-025-64	035-025-94
		15350	035-025-55	035-025-65	035-025-95
		17750	035-025-56	035-025-66	035-025-96
8	15350	035-025-57	035-025-67	035-025-97	
	17750	035-025-58	035-025-68	035-025-98	
	304S	8	15450	042-031-51	042-031-61
17850			042-031-52	042-031-62	042-031-92
10		15480	042-031-53	042-031-63	042-031-93
		17880	042-031-54	042-031-64	042-031-94
404S	12	20280	042-031-55	042-031-65	042-031-95
		17700	052-038-51	052-038-61	052-038-91
		20100	052-038-52	052-038-62	052-038-92
	14	22500	052-038-53	052-038-63	052-038-93
		20100	052-038-54	052-038-64	052-038-94
		22500	052-038-55	052-038-65	052-038-95



## Basic kit



In the basic kit of Furler, stanchion blocks, pre feeder, halyard lead and Torx bits have been excluded.



A stainless steel cover is available as an option. Art. No. 549-228-10 (204S), 549-328-10 (304S) and 549-428-10 (404S).

Furler	Forestay dia. Ø mm	Max. forestay length, mm	Basic kit including...		
			Sta-lok terminal (Standard) Art. nr.	Sta-lok terminal & rigging screw Art. No.	Stud terminal for swaging Art. No.
104S	4	8100	030-020-510	030-020-610	030-020-910
		10500	030-020-520	030-020-620	030-020-920
	5	8100	030-020-530	030-020-630	030-020-930
		10500	030-020-540	030-020-640	030-020-940
		12900	030-020-550	030-020-650	030-020-950
	6	10500	030-020-560	030-020-660	030-020-960
12900		030-020-570	030-020-670	030-020-970	
204S	6	10550	035-025-510	035-025-610	035-025-910
		12950	035-025-520	035-025-620	035-025-920
		15350	035-025-530	035-025-630	035-025-930
	7	12950	035-025-540	035-025-640	035-025-940
		15350	035-025-550	035-025-650	035-025-950
		17750	035-025-560	035-025-660	035-025-960
	8	15350	035-025-570	035-025-670	035-025-970
		17750	035-025-580	035-025-680	035-025-980
		304S	8	15450	042-031-510
17850	042-031-520			042-031-620	042-031-920
10	15480		042-031-530	042-031-630	042-031-930
	17880		042-031-540	042-031-640	042-031-940
404S	12	20280	042-031-550	042-031-650	042-031-950
		17700	052-038-510	052-038-610	052-038-910
		20100	052-038-520	052-038-620	052-038-920
	14	22500	052-038-530	052-038-630	052-038-930
		20100	052-038-540	052-038-640	052-038-940
		22500	052-038-550	052-038-650	052-038-950
		22500	052-038-550	052-038-650	052-038-950





19-strand wire

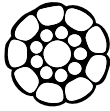

Compact wire (Dyform®)

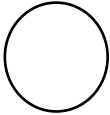

Rod

Furlex	Forestay dia. mm	Rod dia. mm	Max righting moment (kNm) at 30° heel		Approx. displacement, tonnes	
			Masthead rig	Fractional rig	Masthead rig	Fractional rig
104S	4	-	6.5	8	1.4	1.7
	5	-	10	14.5	2.1	3
	6	-	17	22	3.5	4
204S	6	-8 (5.7)	19	23	3.9	4.5
	7	-10 (6.4)	27	34	5.5	7
	8	-12 (7.1) -15 (7.5)	37	45	7.5	9
304S	8	-12 (7.1) -15 (7.5)	40	50	8	10
	10	-17 (8.4) -22 (9.5)	70	80	14	15
	14	-30 (11.1) -40 (12.7)	120	160	20	26
404S	12	-30 (11.1)	120	160	20	26
	14	-30 (11.1)	180	190	28	30
		-40 (12.7)				

Bushings for Navtec, BSI and OYS rods are available from Seldén.  
Furlex is available with compact wire. Just add "C" to the article number, for example 035-025-51C.

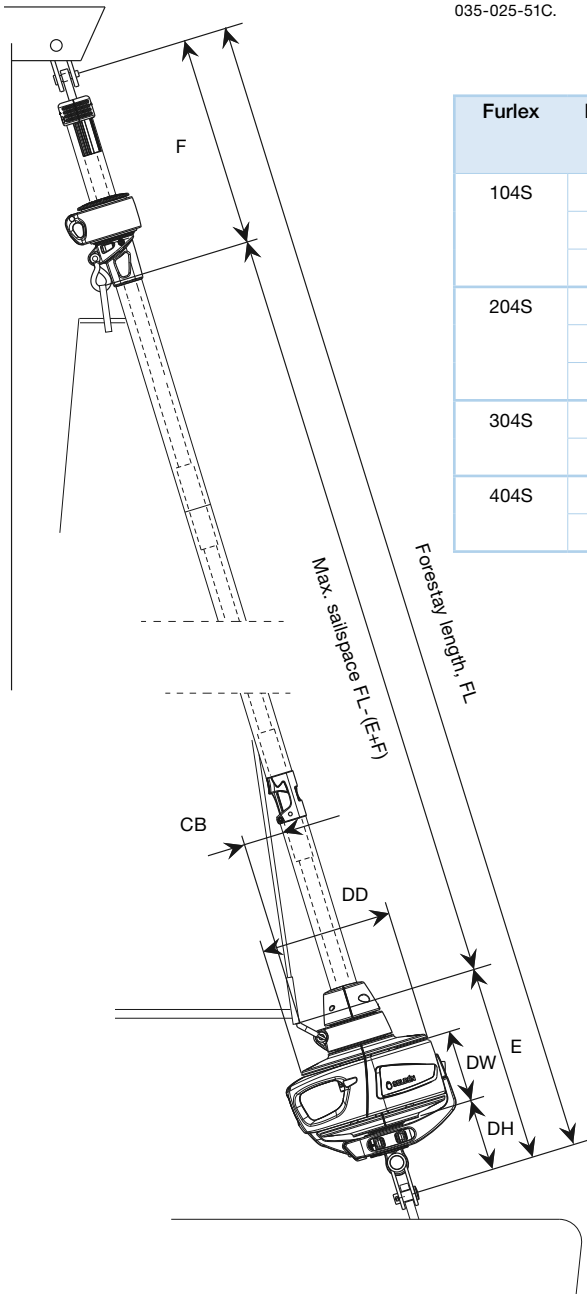

Furlex	Forestay dia. mm	DH mm	DW mm	DD mm	CB mm	E mm	F mm	ID mm	W2 mm	D2 Clevis pin	Forestay adjustment dia., mm
104S	4	85	65	155	60	205	410	17	8.5	8	60
	5	90	65	155	60	205	410	19	11	10	60
	6	100	65	155	60	220	425	24	11	10	60
204S	6	115	90	185	60	265	425	24	11	10	60
	7	115	90	185	60	265	425	24	12.5	12	60
	8	115	90	185	60	275	425	31	15.5	14	60
304S	8	125	105	220	60	310	430	31	15.5	14	80
	10	125	105	220	60	315	530	34	16	16	80
404S	12	170	135	260	80	390	630	40	21	19	100
	14	188	135	260	80	410	630	50	23	22	100

Furlex	Internal diameter of luff groove (DLG), Ø mm	Width of luff groove (WLG), mm
104S	6.0	2.75
204S	6.0	3.0
304S	7.0	3.0
404S	8.0	3.0

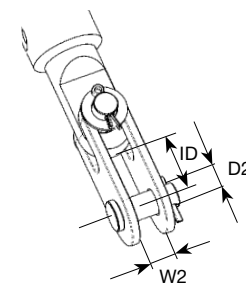

Furlex standard toggle.

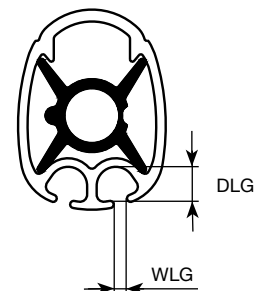

A close-up photograph of a Selden brand pulley block. The block is dark blue with a silver-colored metal sheave and a stainless steel shackle. A white rope with black flecks is visible passing through the block. The Selden logo and name are printed on the side of the block. The background is bright and out of focus, suggesting an outdoor setting like a boat deck.

 **SELDÉN**

# DINGHIESKEELBOATSYACHTS

**Seldén Mast AB, Sweden**

Tel +46 (0)31 69 69 00  
Fax +46 (0)31 29 71 37  
e-mail [info@seldenmast.com](mailto:info@seldenmast.com)

**Seldén Mast Limited, UK**

Tel +44 (0)1329 50 40 00  
Fax +44 (0)1329 50 40 49  
e-mail [info@seldenmast.co.uk](mailto:info@seldenmast.co.uk)

**Seldén Mast Inc., USA**

Tel +1 843-760-6278  
Fax +1 843-760-1220  
e-mail [info@seldenus.com](mailto:info@seldenus.com)

**Seldén Mast A/S, Denmark**

Tel +45 39 18 44 00  
Fax +45 39 27 17 00  
e-mail [info@seldenmast.dk](mailto:info@seldenmast.dk)

**Seldén Mid Europe B.V.,  
Netherlands**

Tel +31 (0)111-698 120  
Fax +31 (0)111-698 130  
e-mail [info@seldenmast.nl](mailto:info@seldenmast.nl)

**Seldén Mast SAS, France**

Tel +33 (0)251 362 110  
Fax +33 (0)251 362 185  
e-mail [info@seldenmast.fr](mailto:info@seldenmast.fr)

**Seldén Mast Asia Ltd,  
Hong Kong**

Tel +852 3572 0613  
Fax +852 3572 0623  
e-mail [info@seldenmast.com.hk](mailto:info@seldenmast.com.hk)

The Seldén Group is the world's leading manufacturer of mast and rigging systems in carbon and aluminium for dinghies, keelboats and yachts.

Our well known brands are Seldén and Furlex. The worldwide success of Furlex has enabled us to build a network of over 750 authorised dealers covering the world's marine markets. So wherever you sail, you can be sure of fast access to our service, spare parts and know-how.

SELDÉN and FURLEX are registered trademarks of Seldén Mast AB.

**[www.seldenmast.com](http://www.seldenmast.com)**



Backed up by sailmakers and riggers -  
worldwide.

SELDÉN and FURLEX are registered trademarks of Seldén Mast AB  
Seldén Mast AB, Sweden e-mail [info@seldenmast.com](mailto:info@seldenmast.com),  
[www.seldenmast.com](http://www.seldenmast.com)

 **SELDÉN**  
for sailing